

CORPORATE BROCHURE



COTECNA

TRIED & TRUSTED

The Cotecna group of companies delivers innovative, efficient and reliable services in the fields of government inspection, scanning, risk management, certification and testing.

2132657

4310

MGW 30,480 KG.
67,200 LBS.

TARE 4,020 KG

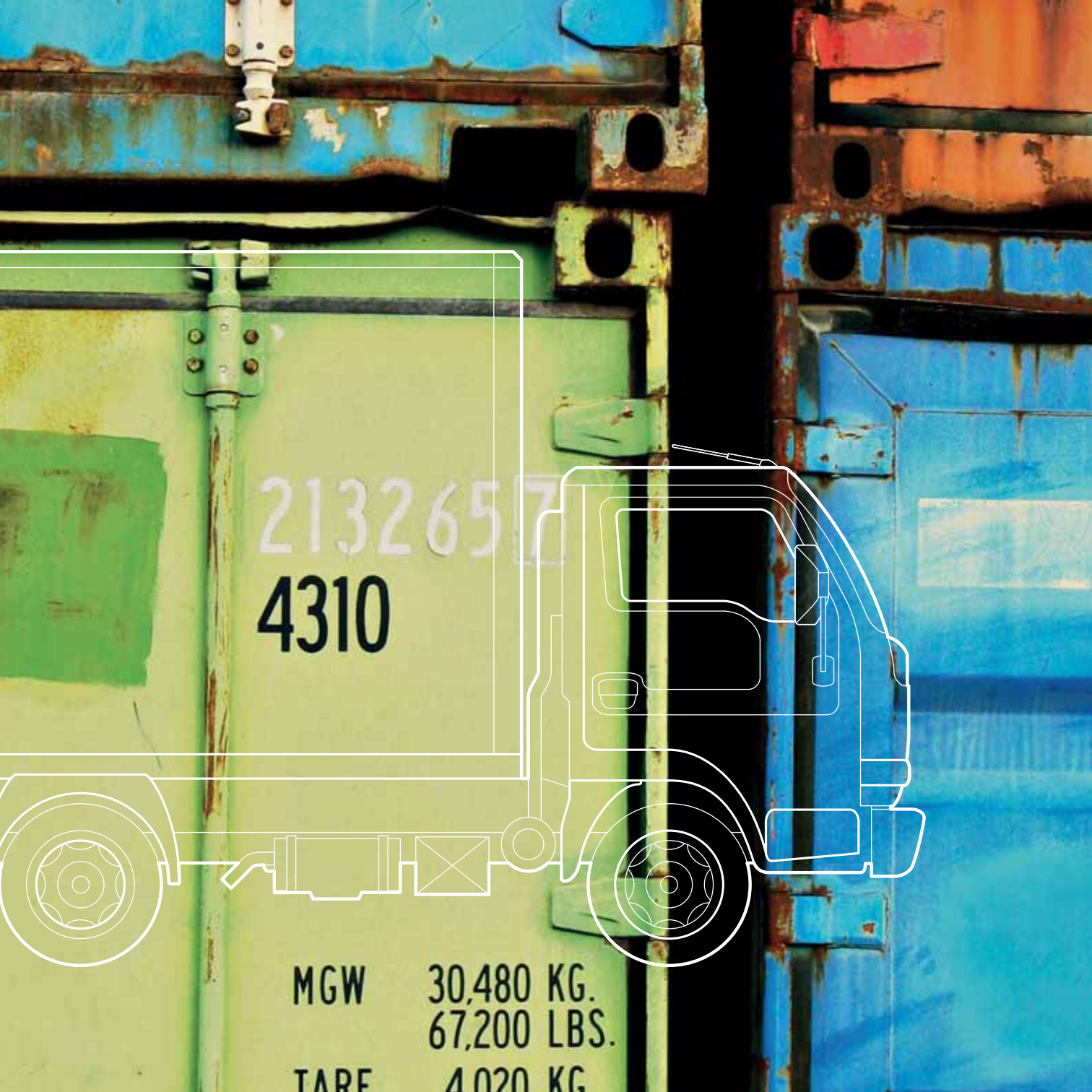

FACILITATING GLOBAL TRADE WITH CUSTOMIZED SOLUTIONS

Cotecna is a Swiss-based multinational company providing a complete range of trade facilitation and inspection services to government and commercial customers. The worldwide leader in Customs government inspection contracts, we specialize in developing innovative, tailor-made solutions that allow governments to combat fraud and protect import tax revenues, maintain internal security, and increase the speed and efficiency of legitimate trade across their borders.

We also cater to commercial customers, offering a full range of inspection, testing and certification services that verify conformity with commercial commitments or standards, as well as trade finance support and electronic documentation services.

We specialize in developing innovative, customized solutions that allow governments to combat fraud and protect import tax revenues.



"The value we place on listening to our customers is one of the strongest drivers of our growth."

Robert Massey, CEO of Cotecna

WORLD-CLASS EXPERTISE AND REACH

Cotecna was founded in Switzerland in 1974 by Elie Georges Massey and remains a family-owned business today. The Group's international network comprises over 100 offices in more than 60 countries, with a workforce of about 4 000 employees and agents. Cotecna combines the professionalism, reliability, infrastructure and expertise of a long-established, world-class player with the flexibility and proximity of a smaller sized company.

Proactive in its approach, Cotecna regularly implements new services adapted to its customers' specific needs. The Group's revenues have risen by more than 120% over the past 10 years and Cotecna presently issues close to 400 thousand government certificates representing a value of over USD 30 billion annually.

ANTICIPATING NEEDS IN A CHANGING ENVIRONMENT

In a constantly changing and increasingly challenging regulatory environment, Cotecna ensures customers' compliance with international norms and legislation and increases their ability to function efficiently. The Group stays abreast of trends and has regularly proven itself a pioneer in the introduction of the latest technologies, such as high-energy cargo scanning and, most recently, secure electronic transfer of bankable documents. Cotecna also plays a significant role in Customs capacity building as developing countries move towards greater autonomy and self-sufficiency.

As emerging markets gain in importance and governments search for creative opportunities to harness the expertise of the private sector, both through Public-Private Partnerships (PPPs) and the outsourcing of trade facilitation services, the industry will expand, and Cotecna expects to play an important role.

"Cotecna has done a most commendable job towards the development of Tanzania. Kudos to you for the destination inspection systems you have put in place since 2004."

Busegi D. Kulwa, Dar VK, Key Accounts Manager at Kuehne+Nagel Ltd

4 0 0 0

EMPLOYEES AND AGENTS

100 OFFICES IN 60 COUNTRIES

120% INCREASE

IN REVENUE SINCE 2000

PROFESSIONALISM, RELIABILITY
EXPERTISE, FLEXIBILITY

STRATEGICALLY EXPANDING

The Cotecna group is well placed in the market, with experience in providing government and commercial services in Africa, Asia, Europe and the Americas. The Group is expanding its activities in all key markets, including Central and Southeast Asia, Central America and Eastern Europe.

With its proven capacity to deliver solutions to clients in all markets, Cotecna is well positioned to take advantage of future opportunities to expand through organic growth and acquisitions.

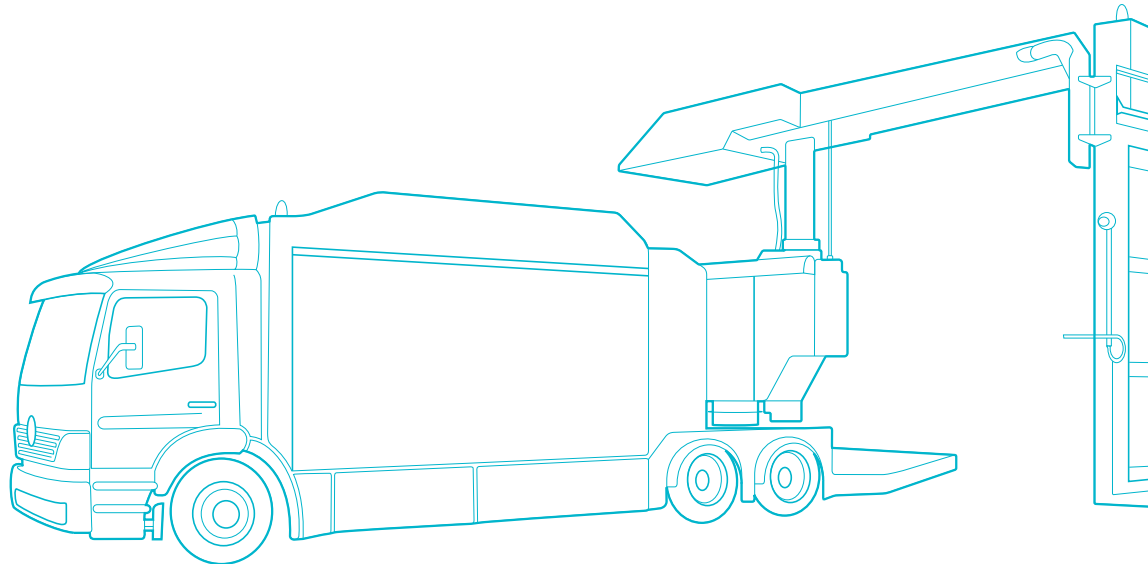

COMPREHENSIVE RANGE OF SERVICES

GOVERNMENT

Cotecna helps its government customers ensure that import tax revenue is based on the fair value of goods and that prohibited, restricted or controlled imports are more readily detected. We also facilitate legitimate trade across borders through the introduction of new technologies and efficient processes, reducing lengthy and costly delays in the import and clearance process. The Group offers an entire spectrum of services to meet these needs, including post-clearance verification, risk management, destination inspection, pre-shipment inspection, non-intrusive scanning, valuation, transit monitoring, and other trade security and facilitation solutions, fully customized to meet the specific needs of our client partners.

COMMERCIAL

Cotecna provides its commercial customers with full Testing, Inspection and Certification (TIC) services. We ensure contractual compliance for a wide range of commodities, including agricultural products, metals and minerals, as well as consumer goods and general cargo. For this purpose, the Group conducts testing of commodities and consumer products through a network of dedicated, accredited regional laboratories. In our quest to provide our customers with innovative solutions, we recently launched our E-dox[®] service, allowing clients to transmit documents electronically using the most advanced encryption technology. Clients of our trade finance support services benefit from our unique on-line administration and reporting tool, Vestalis[®].



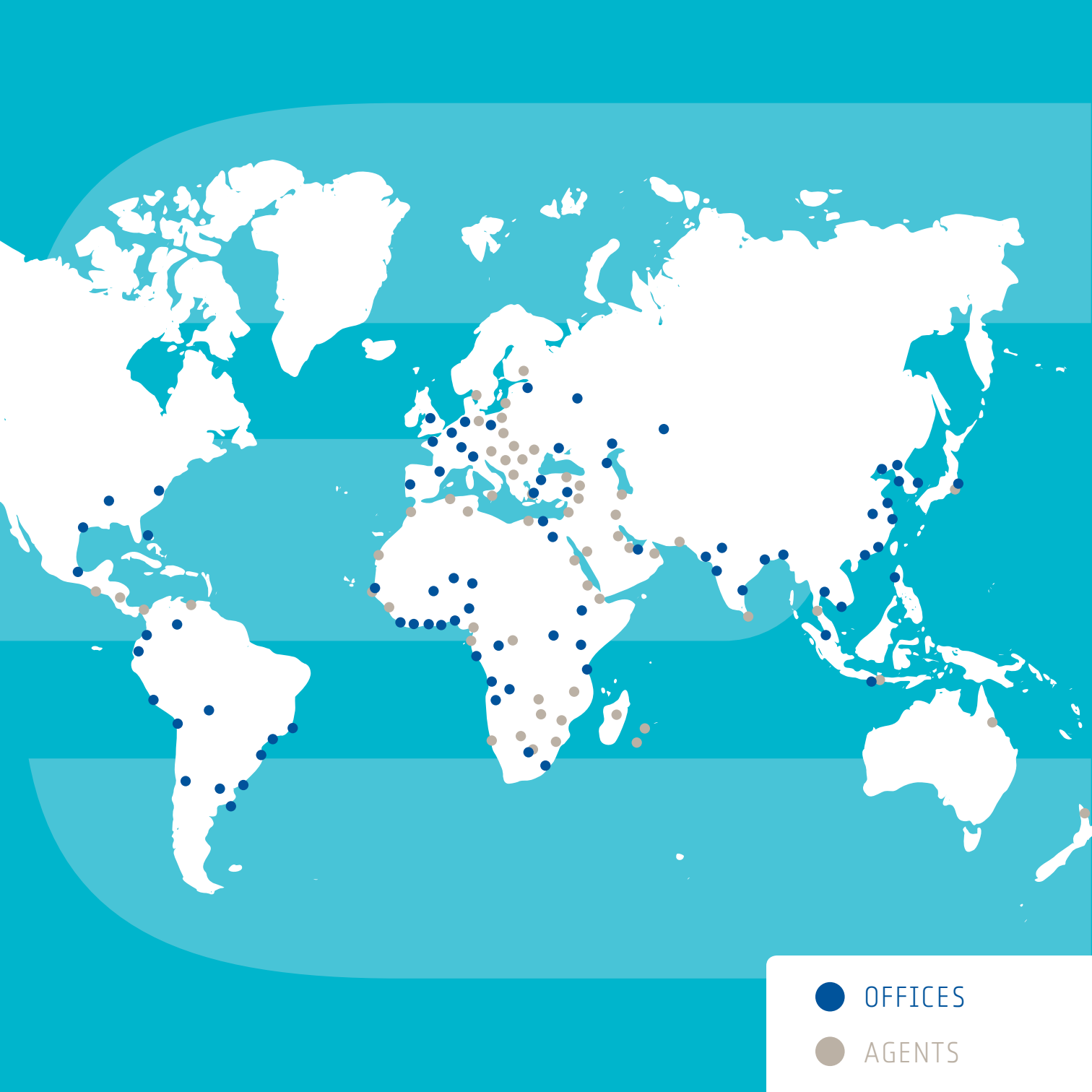

● OFFICES

● AGENTS

PROXIMITY TO OUR CUSTOMERS

Cotecna is a culturally diverse organization with an intimate understanding of regional and country-specific issues. We maintain proximity to our customers, with most managers hired locally. By tapping into our extensive international network, we can readily communicate with all our local partners in their own language and time zone.

TANZANIA SUCCESSFUL INTRODUCTION OF ON-LINE SERVICES

Through our local subsidiary Tiscan, Cotecna has been working closely with the Tanzanian government since 2004 on a broad-ranging modernization initiative involving the successive introduction of new services, as part of a destination inspection contract.

In 2009, Cotecna implemented a program allowing all Customs declarations and forms to be completed on-line without the need for physical visits or hard copies. This measure is having a far-reaching positive impact on the efficiency and cost of trade with Tanzania.

A SKILLED, COMMITTED PARTNER WITH A HANDS-ON CULTURE

Our talented global team has a strongly hands-on corporate culture and prides itself on its ability to operate successfully in difficult environments and meet challenges through innovation. By sharing our in-depth expertise and ideas in an advisory capacity, we allow our customers to rapidly move up the learning curve in acquiring knowledge of processes and technologies. Cotecna's customers justifiably regard us as a true, committed partner.



A SOCIALLY CONSCIOUS CONTRIBUTOR TO THE LOCAL COMMUNITY

Cotecna demonstrates solidarity with the communities in which we operate. Our business activities inherently contribute to the long-term social and economic evolution of developing countries. Besides protecting government revenues, we create jobs and use local suppliers where possible, help governments meet international objectives such as the Millennium Development Goals, and ensure internal security and safety by helping prevent the import of counterfeit drugs, dangerous toys, tainted food, illegal weapons and munitions and instruments of terrorism.

Modern processes also lead to reduced environmental impact, such as through the reduced use of paper documents.

Cotecna's social contributions extend well beyond our core business, with numerous charitable contributions and business-related sponsorships supporting humanitarian projects, focusing especially on clean water, health and education. Just a few recent projects include the financing and support of schools in Nigeria, Burkina Faso, Niger and Congo, the refurbishment of a mammography clinic in Tanzania, and emergency aid in Burkina Faso following torrential rains and flooding.

INTEGRITY IS AT THE CORE OF OUR BUSINESS

Cotecna's entire business model and philosophy are centered on integrity in our relations with our clients, and we place professional ethics above commercial considerations.

We respect confidentiality while maintaining full transparency about our role, deliverables, and what is done with information we handle.

Throughout our organization our employees respect a strict Business Ethics & Compliance Code.

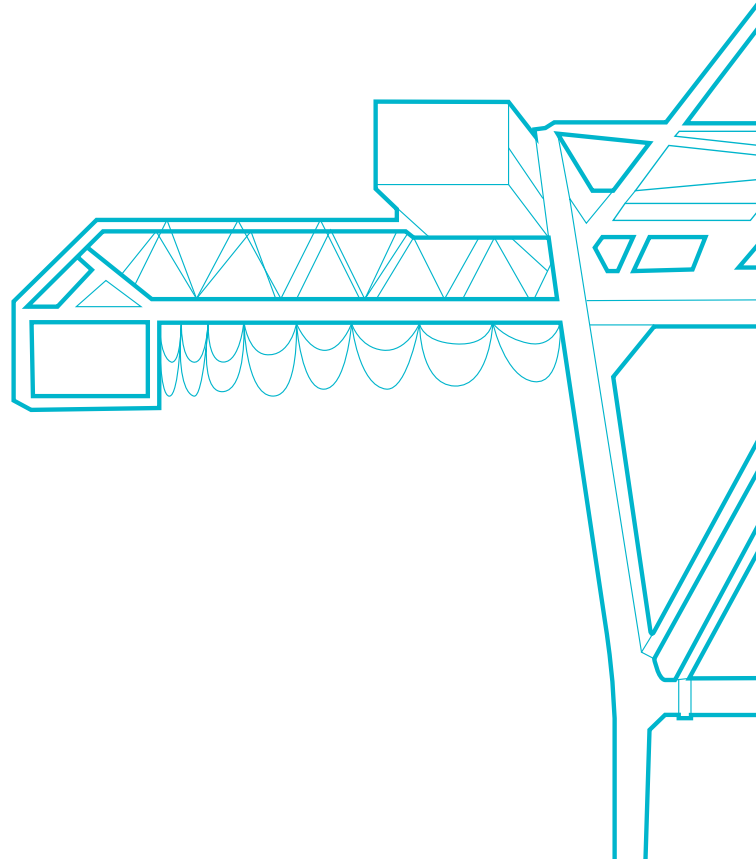

PROXIMITY INNOVATION & EFFICIENCY

These three words represent our corporate values, encapsulating what makes Cotecna a respected leader in the industry.

WWW.COTECNA.COM